

Deletes in LSM

LSM-trees are everywhere

fast writes + competitive reads



How about deletes?
why are deletes important?

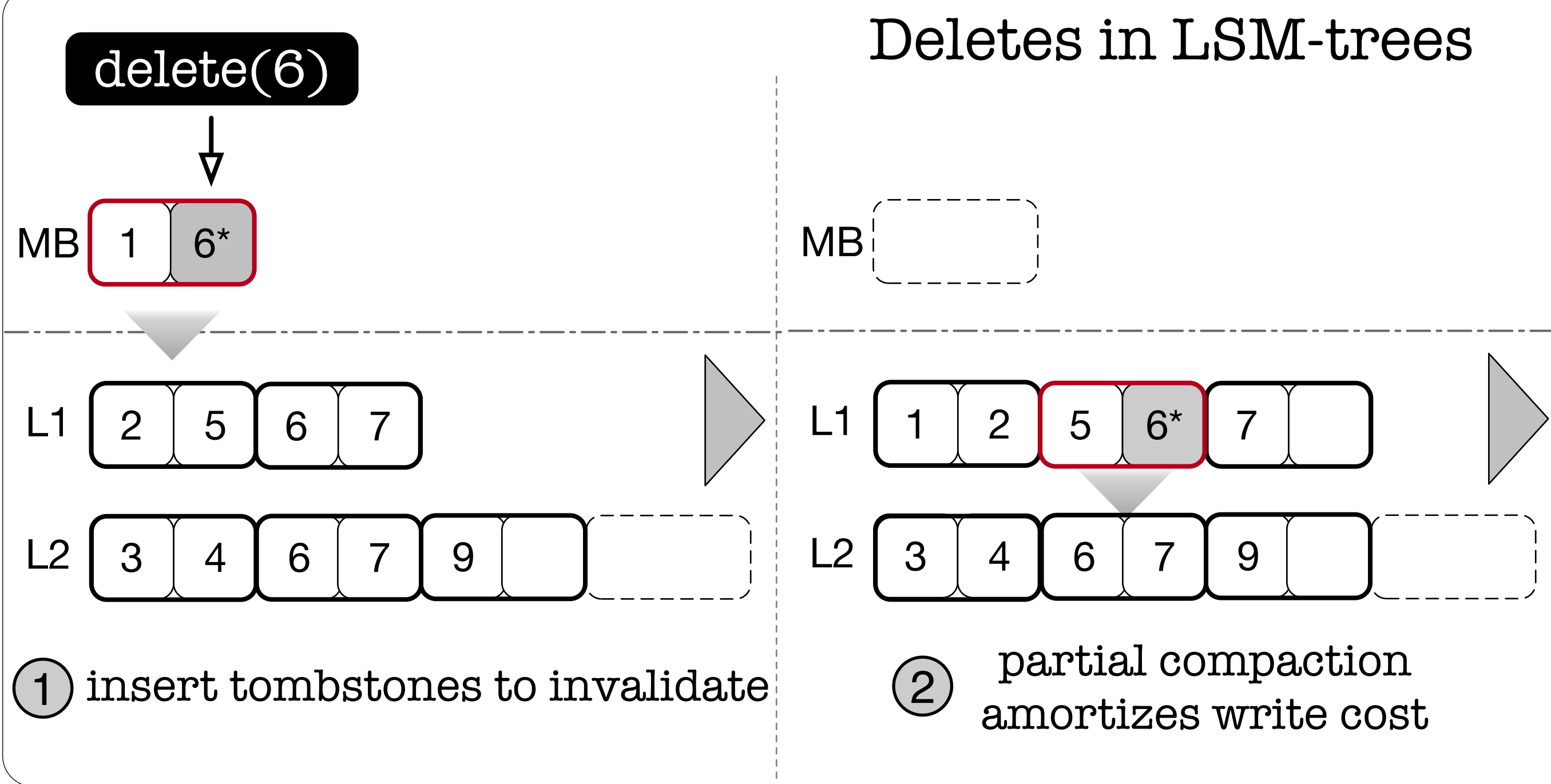

Problem

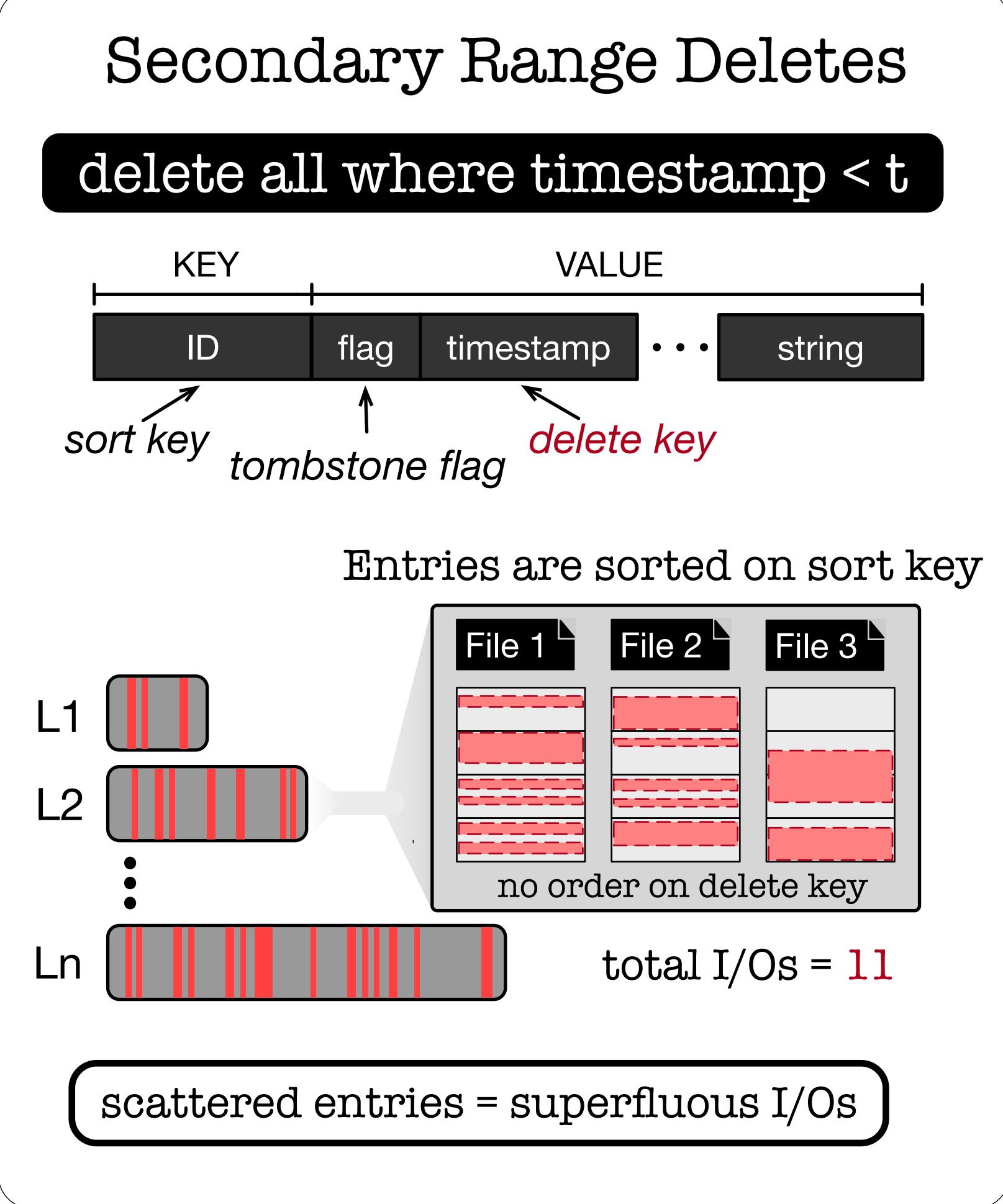
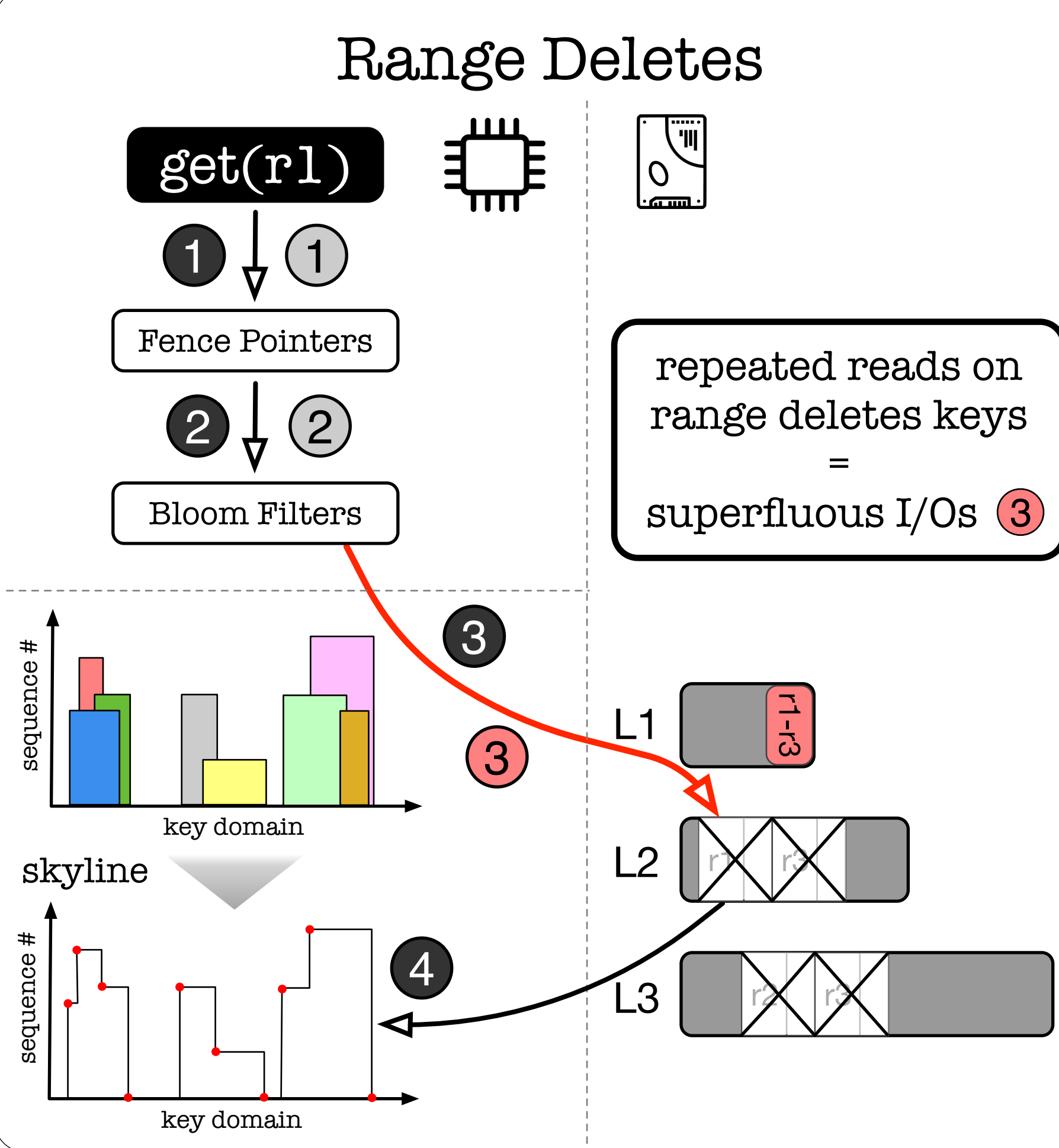
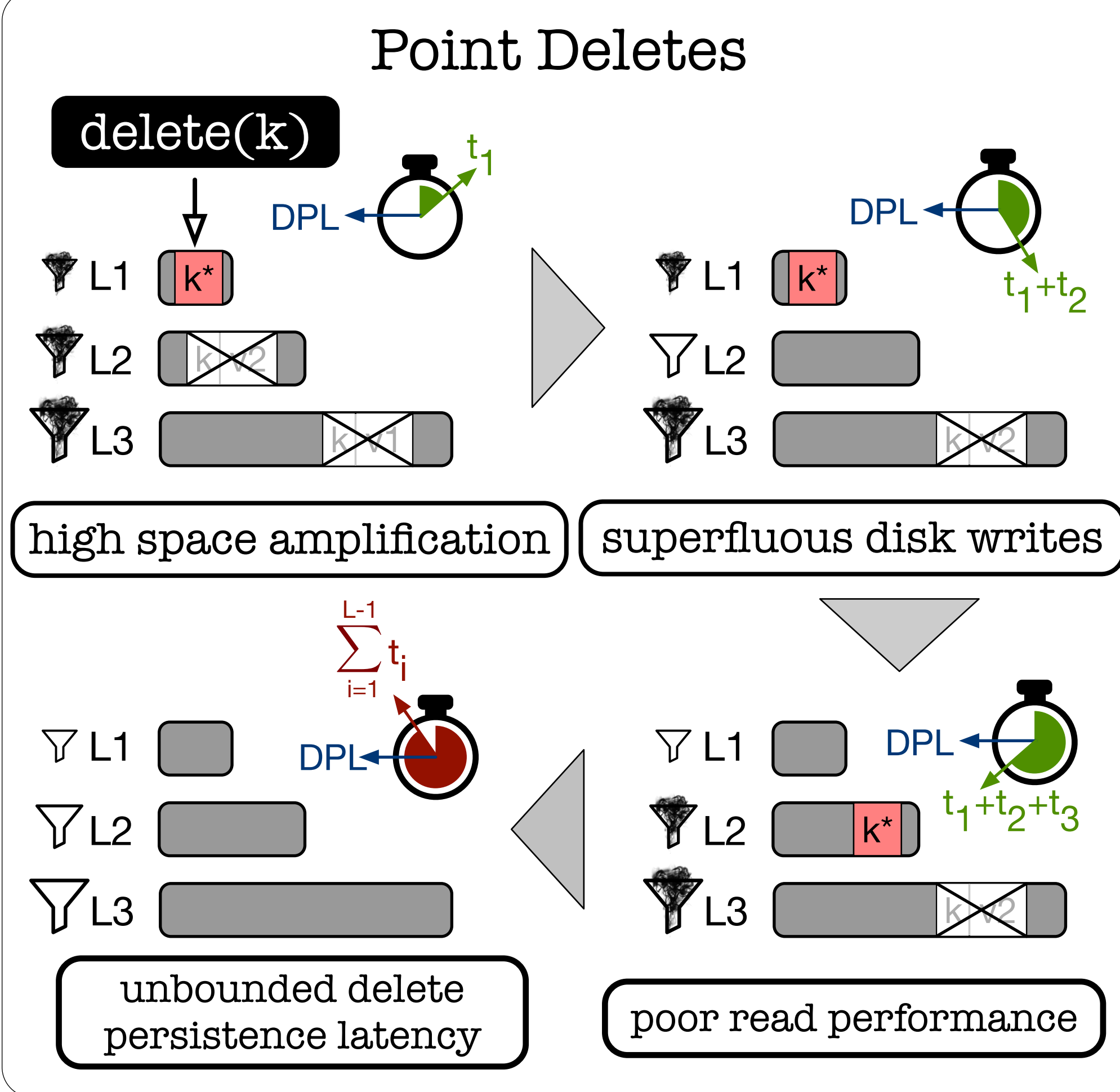

Lethe = FADE + KiWi

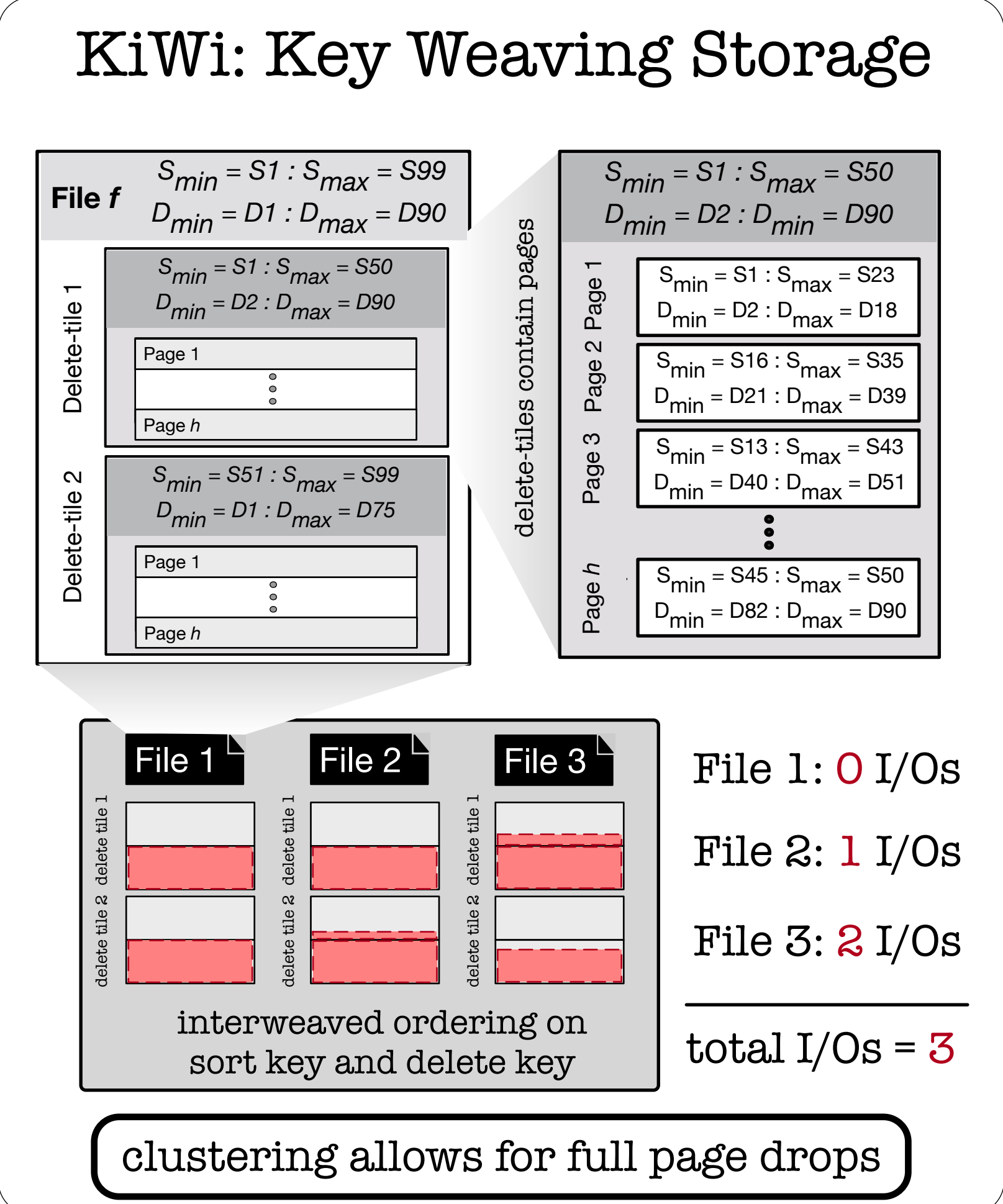
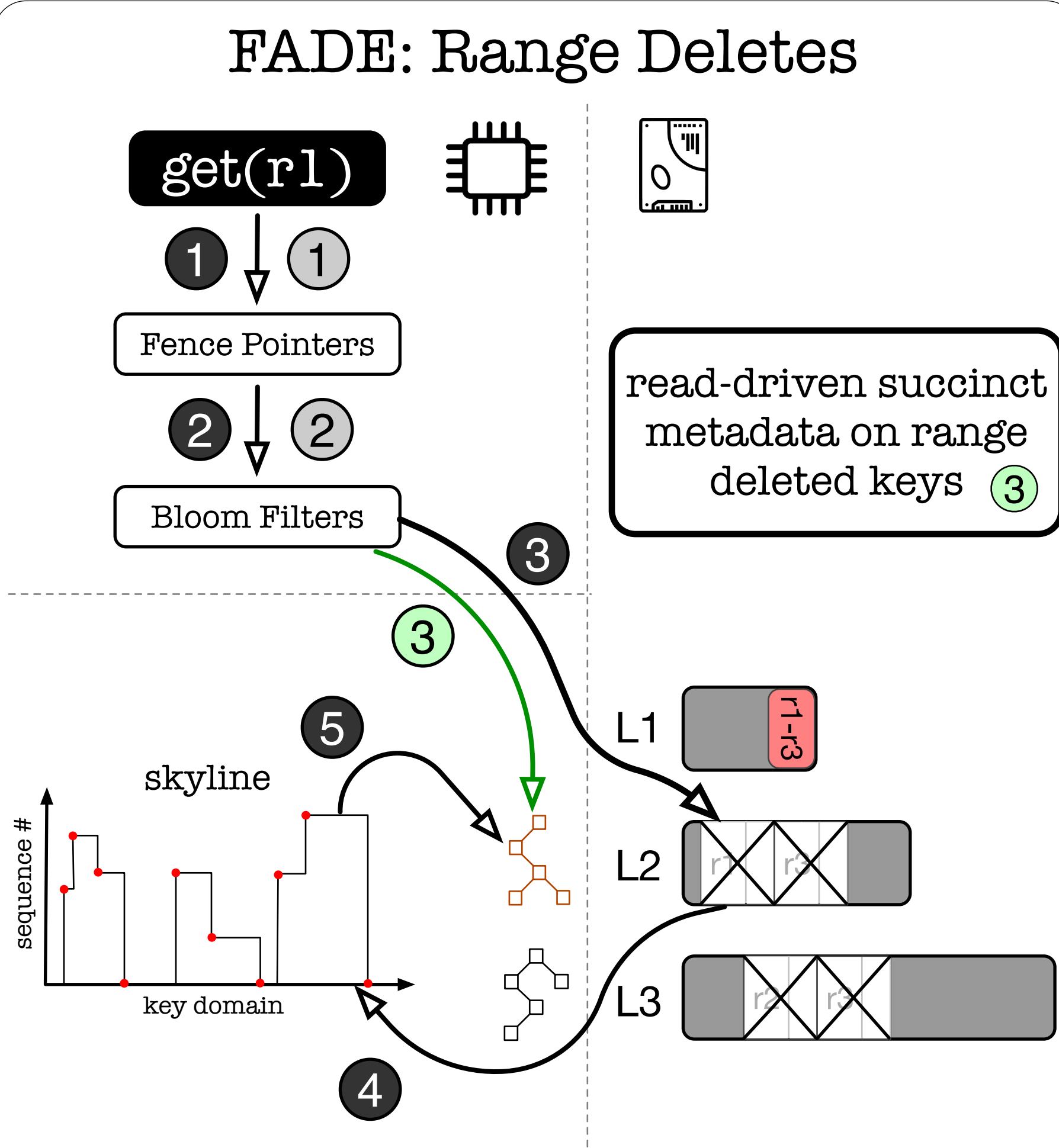
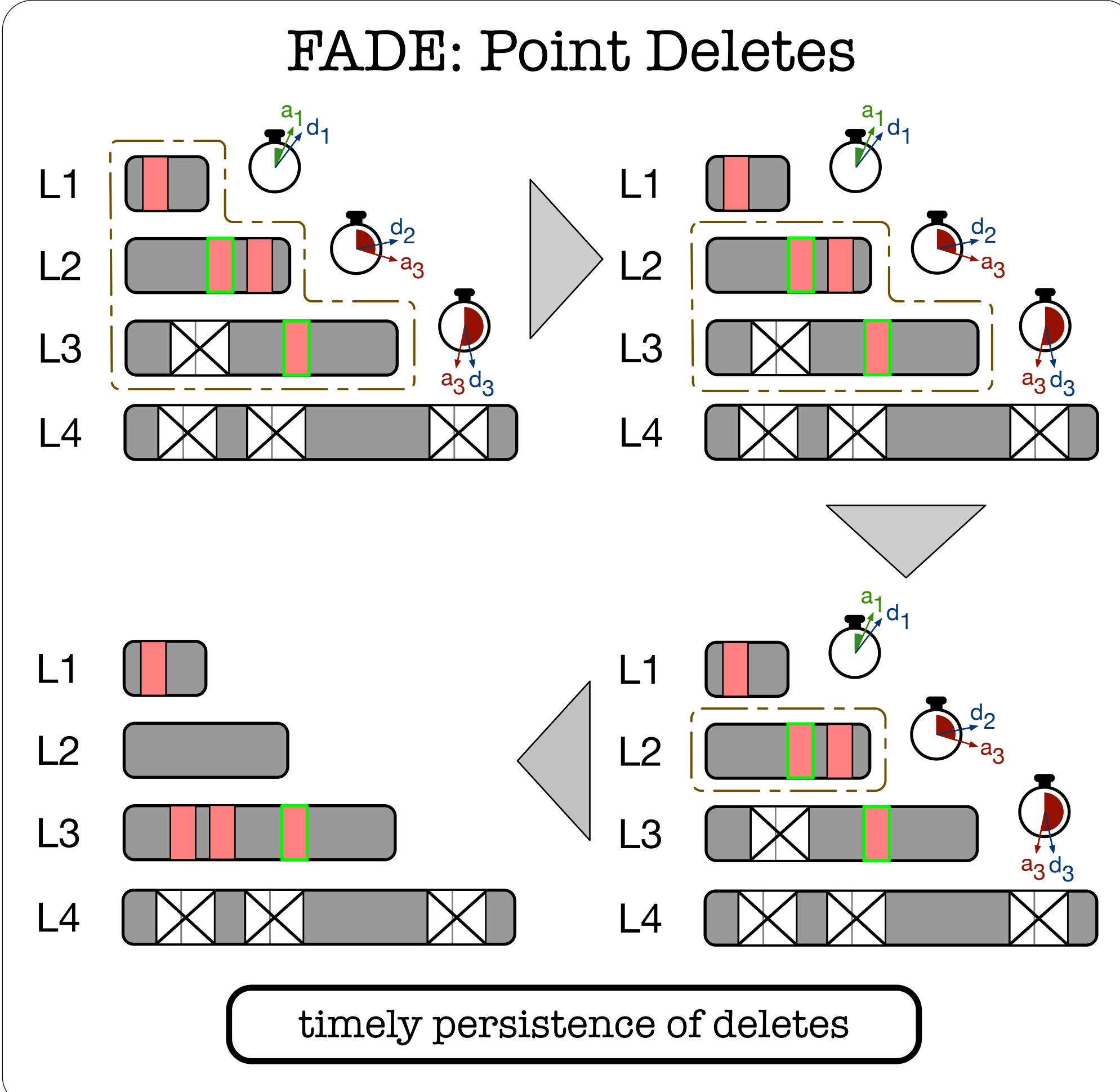

Evaluation

